

# REL

## Operating Instructions

for the

# STORM

## Sub-Bass System

REL Acoustics Ltd  
North Road, Bridgend Industrial Estate  
Bridgend, Mid-Glamorgan, CF31 3TP  
United Kingdom

Telephone: 01 656 768 777; International: +441 656 768 777  
Fax: 01 656 766 093; International: +441 656 766 093

## **WELCOME**

Thank you for buying the REL STORM Sub-Bass system STORM has been carefully hand crafted from the finest materials available and we are sure that it will give you many years of listening pleasure. This manual contains important safety information as well as helpful advice and should be carefully studied before connecting up.

### **World Wide Warranty**

In addition to any local Warranty, REL offer a 3-year conditional Worldwide Warranty to the end user. It is done in collaboration with our Distributors.

The conditions of this Warranty are:

1. That REL receive the necessary registration details from the end user.
2. That these details are received within six weeks of purchase.
3. That the product is not exported from the country of purchase for at least eight weeks after purchase.
4. That any claim is accompanied by the necessary proof of purchase.
5. That it shall be for a term of 3 years from the date of purchase.
6. That the product has not been abused or modified in any way.

This Warranty is offered in good faith and is in addition to any statutory rights or existing Warranty that may be available to the end user.

Should your STORM unit give you a problem, please contact your Dealer who will be able to make whatever arrangements are necessary to correct it.

### **SERVICE AFTER WARRANTY**

Please contact your Dealer in the first instance before returning any product direct to us. Should the unit need to be returned for any reason, all carriage costs will be payable by the Customer. Losses or damage caused during transit are the Customer's risk.

### **WARNING**

**This item is heavy! To avoid risk of injury, take care when handling.**

## CONNECTING UP

Always switch off your system before disconnecting any wires.

To increase the versatility of the choice of connecting up, Storm has three entirely separate sets of input sockets, two Neutrik and one pair of phonos.

The first Neutrik is a dual channel (stereo) unbalanced input at high level designed to accept the much higher level signals from the speaker terminals of the power amplifier. This does have the advantage of ensuring that your STORM receives exactly the same signal as the main speakers. This means that the character of the bass from the main system is carried forward into the sub-bass. This is a very important point and together with the STORM's Active Bass Controller (ABC), ensures far superior system integration of the sub-bass with the main system. So far as we are aware, REL are the only sub-bass manufacturer to take this aspect of performance sufficiently seriously to offer the listener this level of sophisticated control.

The second Neutrik is a single channel high level balanced input designed to take the high level output again from the speaker terminals of bridged monoblocks. (Two Storm subwoofers required, one for each channel).

The low level unbalanced phono inputs would normally be used to source the signal from the "Sub-woofer Output" sockets, where available, from the preamp or Dolby surround sound processor.

Screw the spikes into the feet of the sub-woofer, level them up or if necessary compensate for an uneven floor. It is important that all 4 spikes are located securely and that there is no tendency for STORM to rock. If it does rock, simply adjust one (or more) of the spikes until it fits securely.

### **To Connect to the Power Amplifier: See Fig. 1**

1. Use your existing plugs or connect the STORM Neutrik interconnect to a spare set of speaker terminals. In effect the STORM is bi-wired from your power amplifier. However, note that there are only three connections to STORM. This is deliberate and helps preserve the existing star earthing of your system (assuming it has a star earth arrangement). Connect the Red coloured wire from the Storm Neutrik interconnect to the RED speaker terminal of the right channel of your power amp. Then connect the yellow coloured wire to the RED coloured terminal of the left channel on your power amp. The BLACK wire is connected to either one of the Black terminals of your power amp. Do not connect this black wire to both black terminals - this is important as some amplifiers do not like having their black terminals joined. Connect the Neutrik plug to the high level input on STORM.

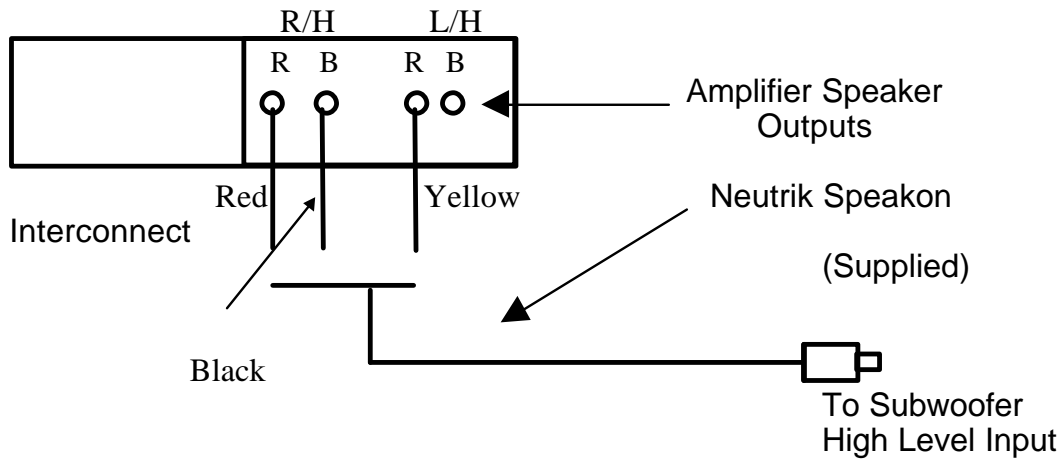

Fig. 1

2. Connect the Mains lead to STORM and to the mains and switch ON.

**To Connect to a Dedicated Sub-woofer Output:  
See Fig. 2**

1. For this connection it will be necessary to use whatever type of connector is needed by this output. Normally it would be a phono type connector. For this method of connection a phono to phono type interconnect is required, available from your dealer.

**Note:-** If only a single phono subwoofer output is available, either use a "y" splitter to connect the two phono plugs from the REL or use a single phono to phono interconnect. This will reduce the volume by 6db.

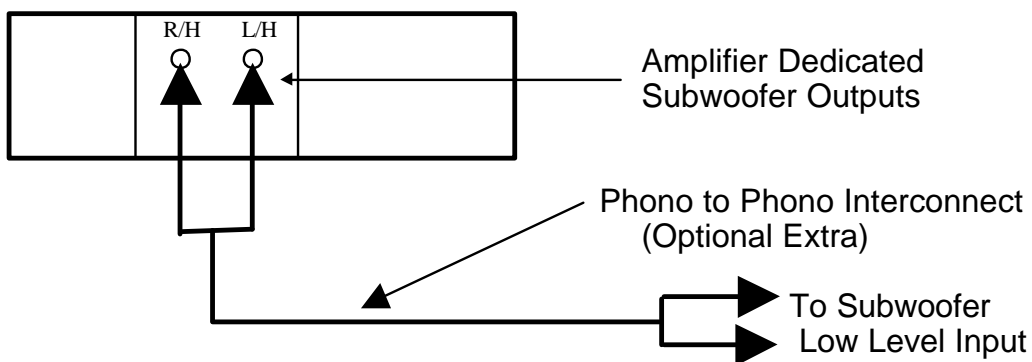

Fig. 2

2. Plug one end of the phono to phono interconnect into the dedicated sub-woofer outputs on your power amplifier or surround processor and the other end into the line level input on STORM.

3. Connect the Mains lead to STORM and to the mains and switch ON.

**To Connect to Bridged ( Monoblock) Amplifiers:  
See Fig. 3**

1. Connect to the amplifier using the Neutrik interconnect supplied with Storm. Connect the RED and YELLOW cores to each of the positive terminals of the amplifier, ( It does not matter which way around the red and yellow are connected ). Connect the BLACK core to ground. **(See your amplifier manual for this ground connection)**

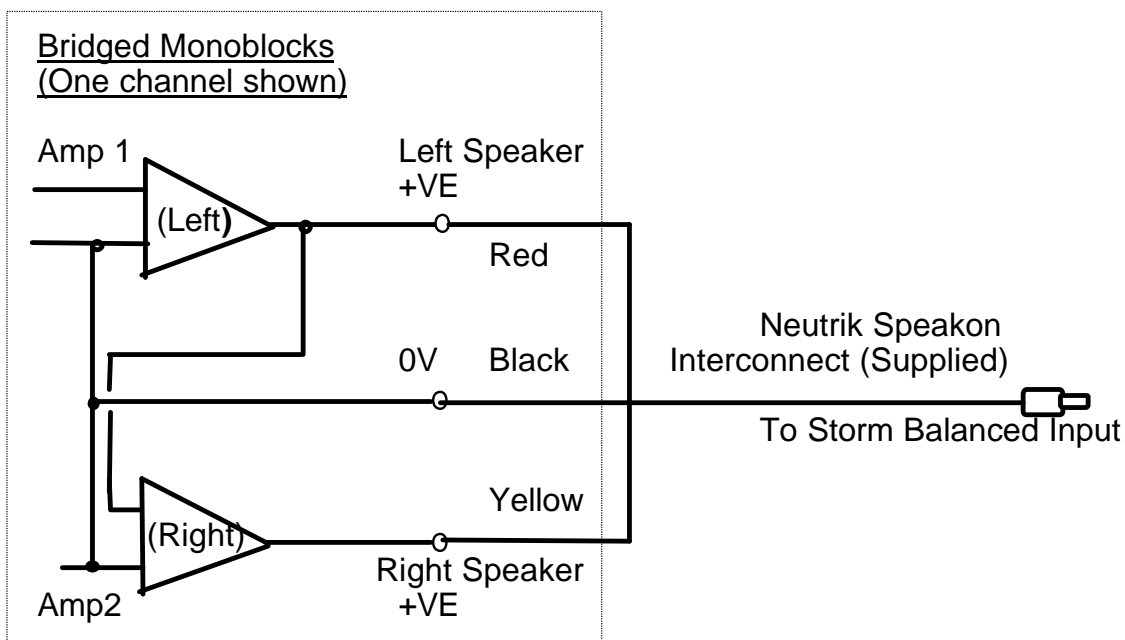

Fig.3

**Note:-**

Two Storm units are required with Monoblocks. Each Storm will sense one channel only.

2. Plug the Neutrik plug into the balanced high level input of Storm.
3. Connect the Mains lead to STORM and to the mains and switch ON.

**SETTING UP**

Initially, test the effect of the controls with STORM sited in any convenient position in your listening room. Check that the phase switch is in the Normal position. Turn the two filter controls fully clockwise (maximum bandwidth) and the gain to minimum. Play some music with known bass content, then adjust the gain control for similar sound levels from your main system and your STORM. Now reduce both filter controls to minimum. Notice that the level of the bass has almost disappeared. This is because these very low frequencies are not being boosted by your room. Without the ABC you would never be able to hear them properly in your room. Increase the Gain control until this deep bass *is* heard. Slowly increase the coarse control one step at a time. If one position appears too much, reduce to the lower setting then increase the Fine control a notch at a time until there is a good match between the two systems. It may be necessary, also, to readjust the Gain control.

Do not worry if it is not immediately obvious which setting is correct. It is sufficient at this stage that you perceive that there are differences and that one is too extreme in each direction, i.e. on maximum settings there is too much bass and at minimum settings there is too little. It will be necessary to test with different types of music with different instruments. At this stage try and get a roughly correct setting.

STORM has a phase reversal switch to allow partial cancellation of the frequencies around the crossover point between the two systems. Listen to the quality of the bass with the phase normal and reversed. Choose the position which subjectively offers the tightest and cleanest bass.

It may take several days before you are completely satisfied that you have found the final best setting. Your acuteness and ability to perceive very subtle differences will improve over these days, possibly because you may not have previously had the opportunity to hear very deep bass in your room. With the ABC you can site STORM almost anywhere you choose. If the bass sounds too prominent, simply reduce one of the filter controls a notch. If there is a "hole", increase one of the filter controls until it is filled in. It is often surprising just how much effect the room is having on the bass response. Sometimes even quite small speakers appear to need very low settings of the ABC. If this is the case, accept it and feel pleased that your stereo imaging extends down so far. It is always better to try and set up for a subtle, rather than an overblown effect if possible. However, personal taste is the over-riding factor here. If it suits your ears, it is correct.

STORM is designed as a true sub-bass speaker. It is designed to reproduce those exceptionally deep notes that are felt rather than heard. This it will attempt to do at whatever volume you set on the gain control on its panel. If set too high the driver cone will simply run out of movement with the lowest notes, causing a "crack" to be heard. If this warning is not heeded and the unit is continuously played in this manner, permanent damage will be done to the driver. This damage is NOT covered by Warranty. Please remember, STORM is there to supplement your main system, not overwhelm it!

## ADVANCED SETTING UP

It is an unfortunate fact that most listening rooms are not perfect. Most suffer from various problems, particularly in the bass. This is why the majority of sub-woofers will not work effectively in most systems - they simply overwhelm the system, causing boom and a poor bass performance. All REL sub-bass systems incorporate special circuitry which we call the Active Bass Controller, or more simply the ABC. The ABC will ensure, when set up accurately, that a REL sub-bass matches into your system precisely. Of course, should you choose to set the controls for a more fulsome bass, or even a totally overwhelming bass, so be it. The REL will oblige!

If your listening room has a rather boomy bass, it may be advantageous to deliberately reverse the phase control on Storm so that partial cancellation of the bass occurs around the crossover frequency between the REL and your main speakers. This will require some patience and care over setting up. But many listeners have reported that what was previously a lost cause, has been totally cured by this simple expedient. Listeners who have had to make do with very small main speakers with a deliberately tapered bass response to offset their poor listening rooms are the ones most likely to benefit from this option. It is impossible to predict the sound experience within a room. We at REL realize this and go to great lengths to offer you, the customer, the means to control the sound within your system. Bass frequencies are often the most troublesome to predict and control. It is one of the reasons why some audiophiles have either given up on trying to reproduce very deep bass within their system or put up with an overblown bass. REL offers the listener the means to control their system sound.

If you are one of the very fortunate few with a superb listening room, then keep your phase switch in its normal position and ignore this advice.

However, this switch also allows you to ensure that any phase reversal within your power amp can be corrected (where the main speakers should then be connected deliberately in reversed phase). Doing this will ensure correct absolute phase of your system.

One of the most frequently reported benefits of owning a REL is the improvement in imaging and depth at ALL frequencies. Many theories exist as to why this should be, but with many listeners, this has been their most pleasing and substantial benefit of owning a REL. Strangely, it often occurs most obviously with those listeners who previously have had the least interest in deep bass! This effect is most pronounced when the REL has been adjusted for the flattest, i.e. not a pronounced bass. It certainly disappears where the listener has it set up to give a deliberately over-blown or boomy bass.

## POSITIONING STORM WITHIN YOUR ROOM

Ideally, STORM should be positioned mid-way between your main speakers but pushed back as far against the wall as possible. This will help with sound integration between the two different sources. It seems that we humans prefer to listen to plane waves rather than spherical. Waves become planar as they travel away from the source, just like waves expanding from a stone dropped in a pond. The further the waves travel, the more planar they become. Perhaps it is because we tend to hear plane waves at a concert or in a Cathedral or any large building, but whatever the reason a more distant source, particularly of low frequencies, appears more interesting. It follows that the very worst place to position a sub-woofer would be just behind the listening chair. Because of the Haas effect (precedence effect of two similar frequencies) we would find such a position very fatiguing if not downright offensive. Fortunately, in the preferred choice of position even with surround sound, very acceptable results can be obtained with a single very low frequency source. Note that these comments apply here because all REL sub-woofers are integrated into the main system by means of the ABC. Thus only very low bass is being generated by the sub-woofer. Such very low frequencies are truly omnidirectional. Unfortunately, with many sub-woofers which cross-over up around 100 Hz, there will be problems because the crossover has a roll-off, it is not a brick wall! Therefore there will be some radiation from such sub-woofers even at 200 to 300 Hz. At these frequencies we **can** detect their source.

If the preferred position is not possible, try moving the sub-woofer to one side or the other. Possibly for a Classical music lover the right hand side may be preferred because the double basses are generally on that side. (This is being very purist of course).

Note that a subtle effect is far more effective at improving imaging and depth than an up front, overblown bass. Tests appear to show that when the bass is made too prominent, the subtle effect of stage depth improvements are completely masked. This may mean a much lower setting of both the filter controls and the gain than might at first have been thought necessary. It is necessary to emphasise that manufacturer's claims for their speaker's in-room low frequency responses should be treated with care. It is far better to trust the results you are getting in the room with your own ears rather than someone else's in their room.

When the final position has been settled, it is better to shorten the signal lead to the ideal length, rather than coiling it up. Although most modern amplifiers are usually exceptionally load tolerant, it is foolish to tempt fate by inviting trouble with a coiled up speaker lead (which is what it is in effect). A shorter lead also minimises the risk of RFI (Radio Frequency Interference). This is more likely than instability today with so many CB enthusiasts around. STORM has internal circuitry designed to reduce the possibility of RFI to almost zero. Unfortunately, many power amps do not. The pick up on the speaker leads (any speaker leads, not just STORM's ) can be fed back on the amplifier's internal negative feedback circuit to



provoke trouble through the main speakers. Where this occurs, shortening the signal leads will usually effect the cure.

## **RUNNING-IN**

Care taken over running-in will be rewarded by many years of pleasurable use. Both the electronics and the drive units will benefit from an initial period of carefully controlled use. During this period, permanent damage can be sustained by running the unit at too high a volume setting. On the other hand, by taking a little care over this initial period, about 24 hours of actual use, a longer life with a higher potential eventual performance is assured

## **CARE AND POLISHING**

The high quality finish is best cared for by using a dampened lint free cloth. Alternatively, a soft bristled brush may be used to sweep off any dust falling on the surface. If objects are to be placed upon the top, it is advisable to use a small mat to protect the surface and to avoid risk of any rattles.

Everything about STORM has been designed and engineered to last a lifetime.

## **SOME DO'S AND DONT'S**

1. Always protect the sub-woofer from getting wet.
2. Always ensure that the panel is correctly earthed via the three core mains cable - it is not sufficient to rely on the earth being made via the signal ground.
3. If the mains lead is lengthened (or shortened) make absolutely certain that the wires are correctly terminated before switching on.
4. In the unlikely event of a fuse failure, always replace by an identical fuse of the same rating and characteristics. A spare mains fuse is located in the sliding drawer of the mains input socket. Further replacements are available from your supplier.
5. Do not attempt to remove the panel or the drive unit from the enclosure - all Warranties become null and void if the seals are broken.
6. Never try to force the switches or the Gain control around further than their normal stops.

7. Do not try to modify or "improve" the design by putting things into the reflex port.

It is not necessary to switch off between listening sessions - it will not significantly shorten its life by leaving it switched on. On the other hand, it will not harm sound quality if it is always switched off. The power consumption in the quiescent state is negligible.

It is perfectly safe under all normal domestic circumstances as it is fully protected.

### **ACTIVE BASS CONTROLLER SWITCH versus CROSSOVER FREQUENCY**

These settings determine the commencement of the upper frequency limit of the sub-woofer. The lowest operating frequency is totally unaffected by these switches.

The 4 steps on the Fine control equal 1 step on the Coarse control

Switch Positions		Frequency
Coarse	Fine	Hz
1	1	30
1	2	33
1	3	36
1	4	39
2	1	43
2	2	47
2	3	52
2	4	57
3	1	62
3	2	67
3	3	73
3	4	80
4	1	88
4	2	98
4	3	108
4	4	120

## SPECIFICATION

Type	Linkwitz-Riley Loading
Enclosure volume	40 litres
Input connectors	Two Neutrik Speakon and one pair phono
Gain control range	40dB
Amplifier type	DC coupled complementary MOSFET
Input impedances:	
High Level Unbalanced	
Two Channel	100K Ohm
High Level Balanced	
One Channel	100K Ohm
Low Level	10K Ohm unbalanced
Power output	100W RMS, 200W Peak
Drive Unit	Heavy duty Cast chassis 26cm
Frequency Range	18 - 120 Hertz
	(Upper frequency dependent on user setting of ABC)
Phasing	Positive or reversed
Mains input Voltage	220-240 or 110-120 V AC to order, via fused I E.C. standard socket with spare fuse in drawer
Dimensions	415mm x 620mm x 330mm (WxHxD) (22.5 x 20.5 x 14 inches approx.)
Weight	30 Kg (66 lbs approx.)
Protection	Internal electronic self-resetting
Fuses	1 x 1.6 Amp semi delay, 240V operation 1 x 3.15 Amp semi-delay, 120 V operation

(Factory selected - do not change without seeking expert advice)

Supplied accessories:	1. Mains lead
	2. 10 metre Neutrik Speakon Interconnect
	3. Operating Manual
	4. Set of 8 mm spikes

**In the interest of product development, REL ACOUSTICS LTD**

reserves the right to vary this specification without notice.

## **Please Note**

**This apparatus is designed to Class II specification and is double insulated, therefore it does not require to be earthed.**

### **UK OPERATION**

This apparatus is supplied with a fitted three pin mains plug. A 5 amp fuse is fitted in the plug. Should the fuse need to be replaced, use a 5 amp fuse approved to ASTA or BSI 1362. Do not use without the fuse cover in place. Replacement fuse covers are available from your dealer.

If for any reason the plug is cut off it must NOT be re-used. Please dispose of any such plug safely. There is a danger of electric shock if the cut-off plug is inserted into a 13A mains socket.

### **IMPORTANT**

The wires in the mains lead are coloured in accordance with the following code:

Green and Yellow	-	Earth
Blue	-	Neutral
Brown	-	Live

As the colours of the wires in the mains lead may not correspond with the markings identifying the terminals in the replacement mains plug, proceed as follows:

- the wire coloured Green and Yellow must be connected to the terminal marked with the letter "E" or with the earth symbol  or coloured Green or Green and Yellow.
- the wire coloured Blue must be connected to the terminal marked with the letter "N" or coloured Black.

- the wire coloured Brown must be connected to the terminal marked with the letter "L" or coloured Red.

Revised July 9<sup>th</sup> 1997, Nov 11<sup>th</sup> 1997

This product is CE marked and has been tested to ensure it satisfies all relevant standards for EN 50081-1 using the limits of EN 55022 class B and IEC 801 - 4 wherever relevant.

It satisfies all tests for Conducted Emissions, Radiated Emissions, Susceptibility and Immunity.

It also complies with the requirements relating to class II construction detailed in clauses 9 & 10 of BS EN 60065 1994.

It also satisfies all relevant safety tests for consumer use provided it is used within the guidelines of this manual.